

2MP EXPLOSION PROOF PTZ CAMERA

ENC-HPT5Z-30X-44

FEATURES

316L (Optional 304) Stainless Steel Construction

30X Optical Zoom, 16X Digital Zoom

ONVIF Profile (S, G, T)

Quad Stream

Wiper Support

SFP Support

ATEX/ IECEx/ CCoE (PESO) Certified

Applicable for GAS Zone 1, Zone 2, Class IIA, IIB, IIC

Applicable for Temperature Classes T1-T6

Applicable for Dust Zone 21, 22

IP66, IP68 (2m/2h)



SPECIFICATION

MODEL	Model No.	ENC-HPT5Z-30X-44
	Type	2MP EXPLOSION PROOF PTZ CAMERA
CAMERA	Image Sensor	1/2.8" CMOS Progressive 2.0 MegaPixel
	Day / Night	IR Cut Filter with Auto Switch
	Lens Type	Motorized Lens
	Focal Length	5 ~ 150 mm (Optional 4.5 ~ 135 mm)
	Focus	Auto / Semi Auto/ Manual
	Iris Type	P Iris (Optional DC Auto Iris), Auto/ Manual
	Angle of View (H)	55.3° ~ 2.3° (Optional 60.0°-2.5°)
	Angle of View (V)	31.2° ~ 1.3° (Optional 33.8°-1.4°)
	Angle of View (D)	63.5°-2.7° (Optional 69.0°-2.9°)
	Aperture Range	F1.6 ~ F4.4
	Optical Zoom	30X
	Digital Zoom	16X
	Electronic Shutter	1s to 1/100,000s, Auto / Manual
	Min. Illumination	Color: 0.001 lux @ F1.6, 0 lux (External IR LED ON)
	AGC	Auto / Manual
Digital Noise Reduction	2D & 3D DNR, Auto / Manual	
S/N Ratio	≥55 dB	
Defog	Smart Defog	
WDR	120 dB	

2MP EXPLOSION PROOF PTZ CAMERA

ENC-HPT5Z-30X-44

MODEL	Model No.	ENC-HPT5Z-30X-44
	Type	2MP EXPLOSION PROOF PTZ CAMERA
DORI	Lens	5 ~ 150 mm (Optional 4.5 ~ 135 mm)
	Detection	101.0 ~ 3060.0 m (Optional 69.8 ~ 2094.8 m)
	Observation	39.7 ~ 1203.0 m (Optional 27.9 ~ 837.9 m)
	Recognition	19.1 ~ 615.0 m (Optional 14.0 ~ 419 m)
	Identification	10.1 ~ 306.0 m (Optional 7.0 ~ 209.5m)
VIDEO	Max. Resolution	1920x1080
	Video Compression	Enhanced (H.265, H.264), H.265, H.264, MJPEG
	Frame Rate	Main Stream: (1920x1080, 1280x720) @ 50/60fps Sub Stream: (1920x1080, 1280x720, 704x576) @ 25/30fps Third Stream: (640x480, 352x288, 320x240, 176x144) @ 25/30fps Fourth Stream: (640x480, 352x288, 320x240, 176x144) @ 25/30fps (Optional)
	Stream Settings	i-Frame, PAL/NTSC, Frame Rate, SVC
	EIS	Supported
	Video Bit Rate	100 kbps ~ 12 Mbps
	Bitrate Type	CBR, VBR
	Image Settings	Brightness, Contrast, Saturation, Sharpness, Day/Night (Color, Mono, Auto), Flip/Mirror/Rotation, Multiple Scene & Profile
	White Balance	Auto, Day / Night, Tungsten, Manual
	HLC	Supported
	BLC	Supported
	OSD	Supported
	ROI	Up to 8 regions
	Privacy Mask	Up to 40 regions (each scene up to 8)
	AUDIO	Audio Compression
Audio I/O		1/1
Audio Bit Rate		64Kbps, 128Kbps
SMART	Behavior Detection	Intrusion (Perimeter), Crossline (Tripwire), Double crossline (Double Tripwire)
	Intelligent Identification	Abandoned object (Object Left), Missing Object (Object Lost), Loitering, Multi Loitering
	Statistical Analysis	Face Detection , People Counting, Human & Vehicle Detection, Abnormal Video & Audio Detection, Wrong Way Detection, Illegal Parking, Tampering / Masking / Scene Change, Abnormal Speed
	Alarm Management	Motion Detection, Tampering (Masking), Input & Output Event, Network Alarm, Disk Alarm, Day Night Switch Alarm, Abnormal Audio Alarm, Pre/Post Alarm Recording, Alarm Recording/Snapshot
INTERFACE	Alarm Notifications	E-mail (Notification & Snapshot), HTTP (Alarm icon), FTP (Snapshot & Recording), SD Card (Recording)
	Protocols	TCP/IP, UDP, IPv4, IPv6, ICMP, HTTP, HTTPS, FTP, DHCP, DNS, DDNS, RTP, RTSP, RTCP, PPPoE, NTP, UPnP, SMTP , IGMP, 802.1X, Unicast, Multicast, QoS, ARP, SNMP, Telnet, SSL/TLS1.2
	Security	TLS 128 Encryption, IP Filter, User Authentication (Multiple Privilege Level), 802.1X Authentication (EAP-MD5), HTTPS Authentication, RTSP Authentication, Digest Authentication, User Access Log
	Compatibility	ONVIF (S,G, T) , SDK, CGI
	Network	1 x RJ45 10M/100M Self Adaptive Ethernet Port
	Optical Fibre Connector	Single mode, FC Type
	Alarm I/O	1/1
	Serial Interface	1xRS485
	Edge Storage	SD card slot, up to 512 GB
	ANR	Supported
	Built-in Heater	Supported
Wiper	Supported	
Max. User	32	
Client Application	EyeGuard	

2MP EXPLOSION PROOF PTZ CAMERA

ENC-HPT5Z-30X-44

MODEL		ENC-HPT5Z-30X-44
Type		2MP EXPLOSION PROOF PTZ CAMERA
PAN AND TILT	Pan Range	360°(Endless)
	Pan Speed	Pan Manual Speed: 0.1°/s ~ 45°/s, Pan Preset Speed: 45°/s
	Tilt Range	-90 ~ +90°
	Tilt Speed	Tilt Manual Speed: 0.1°/s ~ 45°/s, Tilt Preset Speed: 45°/s
	Preset Accuracy	±0.1°
	3D Position	Supported
	Cruise Scan	Supported
	Tour	12 (32 Preset per Tour)
	Pattern	6
	Preset	255
Resume function		Supported
GENERAL	Power Supply	AC 110V ~ 240V / 24V DC / 24V AC / PoE++ (802.3bt-Type 4)
	Max. Power Consumption	≤75W (with thermostat)
	Working Temperature	-40°C ~ 70°C
	Working Humidity	≤95% RH (non-condensing)
	Atmospheric pressure	80 kPa ~ 120 kPa
	Window glass	Strong tempered glass
	Sun shade	Supported
	Ingress Protection	IP66, IP68(2m/2h)
	Surge Protection	TVS6000V
	Reset Button	Supported
Dimensions		390x295x420 mm
Net Weight		40 kg

Dimension Unit : mm

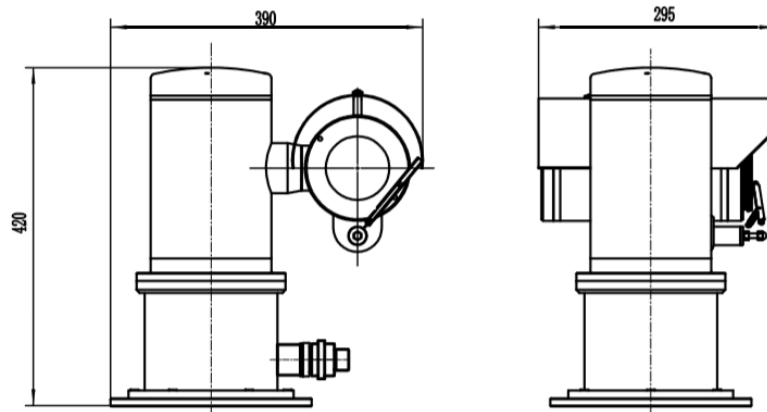

2MP EXPLOSION PROOF PTZ CAMERA

ENC-HPT5Z-30X-44

ORDERING INFORMATION

Part Number	Description	Standard Quantity
ENC-HPT5Z-30X-44	2MP SS316L (optional SS304) 60fps Explosion Proof IP PTZ Camera with 30X Optical Zoom, Wiper, SFP and SD Card Slot Support	1
ENB-BZPW68	Wall Mount Bracket for Norden Explosion / Corrosion Proof PTZ Camera	1
ENB-BZPH68	Corner Mount Bracket for Norden Explosion / Corrosion Proof PTZ Camera	1
ENB-BZPV68	Pole Mount Bracket for Norden Explosion / Corrosion Proof PTZ Camera	1
ENA-EXH010	1 Meter Explosion / Corrosion Proof Hose for Norden Explosion / Corrosion Proof Camera	1
ENA-EXH015	1.5 Meter Explosion / Corrosion Proof Hose for Norden Explosion / Corrosion Proof Camera	1
ENA-EXH020	2 Meter Explosion / Corrosion Proof Hose for Norden Explosion / Corrosion Proof Camera	1

PACKING INFORMATION

Part Number	Packing Mode	Gross weight(Kg)	Dimension(mm)
ENC-HPT5Z-30X-44	Carton Box	-	-